

VP-324 24 VOLT DC POWER SUPPLY

GENERAL

These instructions provide identification, installation, connection, and operation information for the VP-324, 24 Volt DC Power Supply offered by Valcom, Inc., 1111 Industry Avenue, Roanoke, VA 24013.

IDENTIFICATION

System Design

The VP-324 is a non-regulated "unfiltered Signal Battery" which provides 24 VDC .25 amp power supply. The output is floating with respect to ground. Short circuit protection is provided.



Applications

- Valcom one-way amplified speaker assemblies
- Any application where 24 VDC unfiltered signal battery is required

Features

- Non-regulated 24 VDC "B" battery
- Thermal overload protection
- Floating output
- Short circuit protected
- Provides 6 Valcom power units

Capacity

- Current .25 amp at 25 degrees C

Dimensions

- 3.0"H x 2.5"W x 2.0"D
(7.62cm H x 6.35cm W x 5.1cm D)

Specifications

- Output: 24 VDC +/- 3 V "B" battery

Power Requirements

- Input 105-120 VAC, 60 Hz, 18 watts

Environment

- Temperature: 0 to 50 degrees C
- Humidity: 0 to 85% non-precipitating

INSTALLATION

The VP-324 is a receptacle mount power supply designed to be used with a third wire grounded receptacle. A cold water pipe or earth ground should be connected to the local ground screw terminal using 14 AWG ground wire. If a two wire adapter is used, make sure the ground tab is bonded to the local electrical ground.

When the VP-324 is being used with Valcom page control equipment, connect a strap between the local ground and the "+" terminal of the power supply.

When installing Valcom one-way amplified horns, connect the white and black wires of the horn to the power supply "-" and "+" terminals respectively.

When installing Valcom one-way amplified speakers, connect the -24V and ground terminals of the speaker to the power supply "-" and "+" respectively.

947324

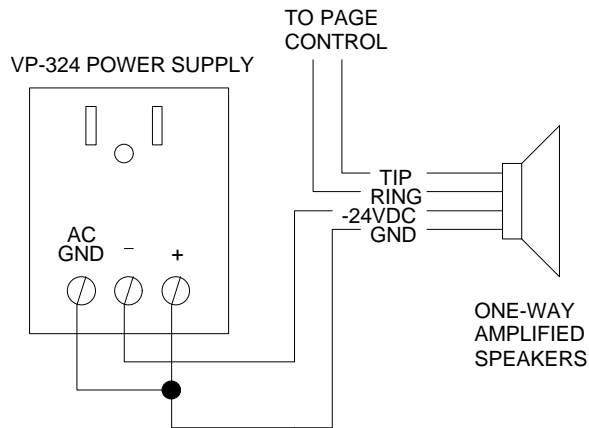

Connections to One-Way Amplified Speakers

Note: The VP-324 power supply is normally used for powering amplified speakers

TECHNICAL ASSISTANCE

When trouble is reported, verify that AC power is being supplied to the unit.

To test the power supply, remove all output connections and measure the output voltage with a meter. The voltage should be 24 VDC +/- 3V. If no voltage is measured, replace the unit.

Assistance in troubleshooting is available from the factory. When calling, you should have a VOM and a test set available and be calling from the job site. Call (540) 427-3900 and ask for Technical Support or call (540) 427-6000 for Valcom 24-hour Automated Support.

Valcom equipment is not field repairable. Valcom, Inc. maintains service facilities in Roanoke, VA. Should repairs be necessary, attach a tag to the unit clearly stating your company name, address, phone number, contact person, and the nature of the problem. Send the unit to:

Valcom, Inc.
Repair and Return Dept.
5614 Hollins Road
Roanoke, VA 24019-5056

VALCOM LIMITED WARRANTY

Valcom, Inc. warrants its products to be free from defects in materials and workmanship under conditions of normal use and service for a period of one year from the date of shipment. The obligation under this warranty shall be limited to the replacement, repair or refund of any such defective device within the warranty period, provided that:

1. inspection by Valcom, Inc. indicates the validity of the claim,
2. the defect is not the result of damage, misuse, or negligence after the original shipment.
3. the product has not been altered in any way or repaired by others and that factory sealed units are unopened (A service charge plus parts and labor will be applied to units defaced or physically damaged),
4. freight charges for the return of products to Valcom are prepaid,
5. all units 'out of warranty' are subject to a service charge. The service charge will cover minor repairs (Major repairs will be subject to additional charges for parts and labor).

This warranty is in lieu of and excludes all other warranties, expressed or implied, and in no event shall Valcom, Inc. be liable for any anticipated profits, consequential damages, loss of time or other losses incurred by the buyer in connection with the purchase, operation, or use of the product.

This warranty specifically excludes damage incurred in shipment. In the event a product is received in damaged condition, the carrier should be notified immediately. Claims for such damage should be filed with the carrier involved in accordance with the F.O.B. point.

Headquarters:
 Valcom, Inc.
 1111 Industry Avenue
 Roanoke, VA 24013
 Phone: (540) 427-3900
 FAX: (540) 427-3517

In Canada
 CMX Corporation
 35 Van Kirk Drive #11 and 12
 Brampton, Ontario L7A1A5
 Phone: (905) 456-1072
 FAX: (905) 456-2269