



(540) 427-3505

# STPA TELEPHONE PAGE ADAPTER

## INTRODUCTION

The STPA is a Telephone Page Adapter used to interface Clarity mixer-amplifiers to Centrex lines, C. O. lines and PABX station numbers. This instruction contains the specifications and guidelines necessary to install, operate, and maintain the STPA which is manufactured by Clarity, 1111 Industry Avenue, Roanoke, VA 24013.

This paging unit has received FCC type KX registration. This Registration Number will be listed in the affidavits filed with the telephone company; it will also be recorded in the system log kept by installation and maintenance personnel. The local telephone company is to be notified of the FCC Registration Number and Ringer Equivalence Number. FCC Registration Number: BAF9I7-13957-OT-N; Ringer Equivalence Number: 1.1A. The STPA connects to the telephone line by means of a standard jack called the USOC RJ11C.

In accordance with FCC Rules with application tariffs, the Page Adapter may only be installed with the authorization of the owner of the host system.

## DESIGN

### General

The Clarity STPA Expandable Station Level Page Adapter is designed to provide access to paging from a standard PABX station number, a Centrex number, or a Central Office line. The unit is directly connected to Clarity mixer-amplifiers. Multiple Telephone Page Adapters with mixer-amplifiers may be used to provide multizone paging.

### PABX Station Level Paging

NOTE: Before proposing Station Level Paging for your PABX perform the following test:

1. Dial between two stations on the PABX and answer the call.
2. Have the called party listen after the calling

- party hangs up.
3. After calling party release, what does the called party hear?

If the PABX IMMEDIATELY returns any type of tones to the called party (dial tone, reorder tone, etc.) then STATION LEVEL PAGING CAN NOT BE USED. Consult your Clarity catalog for an appropriate trunk level page adapter. If there is a delay of at least 10 SECONDS before any tones are returned, then one-way paging may be used but talkback paging will be impossible. If the line REMAINS SILENT after disconnect, then one-way or talkback paging may be used.

If the type of paging you desire is possible on a station level of your PABX, then continue in this section to determine the equipment required.

1. One Zone of One-Way Paging  
This arrangement will require one PABX station number, one STPA page adapter, appropriate Clarity mixer-amplifier, and speaker assemblies.
2. Multi-Zone One-Way Paging with All Call  
This arrangement will require a PABX station number and STPA for each zone, and an additional number and STPA for All Call.

### Centrex or C. O. Line Access to Paging

1. One Zone of One-Way Paging  
One zone of one-way paging will require one Centrex or C. O. Line, a STPA, and the appropriate speakers.
2. Multi-Zone One-Way Paging with All Call  
This arrangement will require a PABX station number and STPA for each zone, and an additional number and STPA for all call.

947421

## SPECIFICATIONS

### Applications

- Loop start central office lines
- PABX station numbers
- Centrex numbers

Refer to Figure 1 for a block diagram of a typical PABX installation.

### Features

- Ring trip on first ring
- 600 ohm output; 8 ohm output with AGC
- Multiple units may be used for multi-zone paging with all call behind a PABX
- Music input
- Open loop detect
- Audio sensing circuit for reset
- Time out reset
- Manual reset
- Answer verification tone
- All call override tone
- Battery reversal indicator
- Auxiliary form C contacts
- Built-in connecting lock
- Powered by a receptacle mount power supply (included)

### Limitations

When used with a PABX, the PABX must not return any tones to the called party after calling party disconnect on a station to station call.

### Capacity

- Each STPA, when connected to its own PABX station number, will provide one zone of paging.
- Use a STPA and a station number per zone for multi-zone paging behind a PABX.
- An additional station number and STPA may be used to provide all call or override in a one-way multi-zone system behind a PABX.

### Dimensions

- 8.25"H x 4.65"W x 2.25"D  
(20.96 cm x 11.81 cm x 5.72 cm)
- 1.5 lbs. (.68 Kg)

### Nominal Specifications

Tip and Ring Input	600 ohms
Voltage for Ring Trip	75-105VAC, 20 or 30Hz
Ring trip timing	150 ms
Open loop detect	150 ms starting 1 second after ring trip
Audio sense release	4, 8, 16, 32, or 64 seconds after audio drops below -22dbm

Time out release	4, 8, 16, 32, or 64 seconds
Manual reset	25 ms ground
Output 1:	
Impedance	600 ohms
Page level	Output level = input level -1 db
Music level	Output level = input level
Output 2:	
Impedance	8 ohms
Page level	-10dbm
Music level	-17dbm
Music Source	8 to 600 ohm -10 to -18 dbm
Answer verification tone	500hz, 500 ms
All call override tone	500 hz, 250 ms on, 250 ms off
Form C Contacts	24 VDC, 3.0 amps or 105 VAC, 1.5 amps

### Power Requirements

-21.5 to -26 VDC "B" Battery, 200 ma max. (power supply included)

### Environment

Temperature: 0 to 50 Degrees C  
Humidity: 0 to 85% non-precipitating

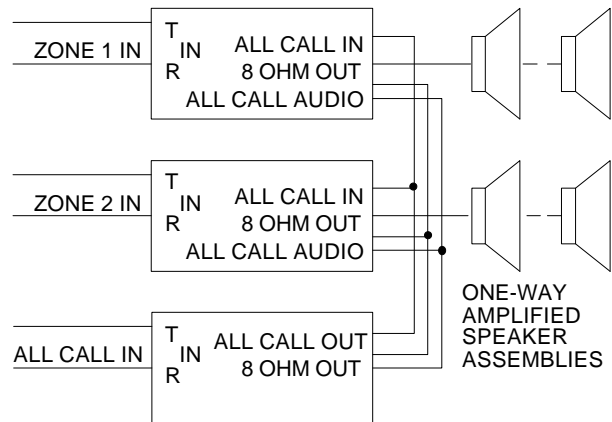

FIGURE 1  
BLOCK DIAGRAM OF A TYPICAL PABX INSTALLATION

## INSTALLATION

### Instructions

Each instruction is preceded by a line. Place a check on the appropriate line as the instruction is completed. The instructions also include tests along the way to verify connections have been made correctly. If these steps are followed properly, installation of the Clarity system will go smoothly and quickly. If the results of a test do not correspond with what is shown, **Do Not Proceed Until the Problem has been Corrected.**

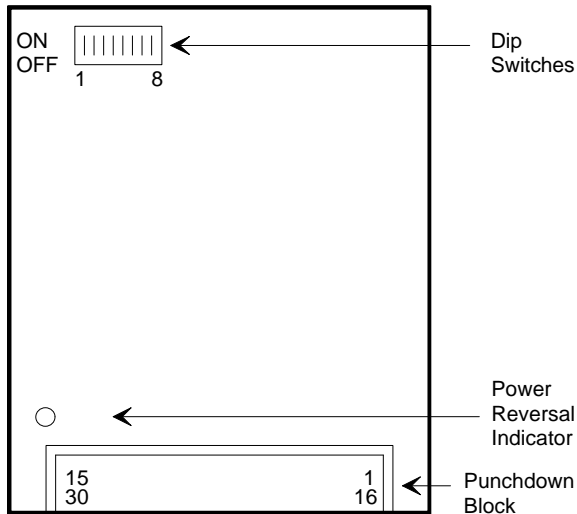

FIGURE 2  
LOCATION AND NUMBERING OF  
PUNCHDOWN BLOCK AND DIP SWITCHES

FIGURE 3 - PUNCHDOWN BLOCK PINOUTS

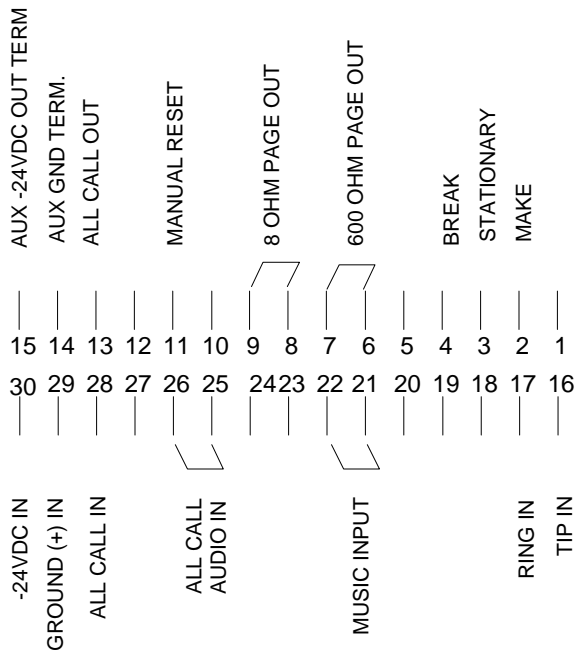

FIGURE 4 - DIP SWITCH SETTINGS

SW	OFF	ON
1	Audio Sense	Time Out Enable

	Enable	
2	Not 1 Sec.	1 Second
3	Not 64 Sec.	64 Seconds
4	Not 32 Sec.	32 Seconds
5	Not 16 Sec.	16 Seconds
6	Not 8 Sec.	8 Seconds
7	Not 4 Sec.	4 Seconds
8	Loop Detect Disable	Loop Detect Enable



## POWER CONNECTIONS

NOTE: Power is required for each STPA being used. If multiple units are being installed, power for additional units may be multiplexed from pins 14 and 15 of a preceding unit (pin 14 is "+" and pin 15 is "-").

- \_\_\_ 1. Connect -24VDC from power supply to pin 30 on STPA.
- \_\_\_ 2. Connect 24VDC Ground "+" from power supply to pin 29.
- \_\_\_ 3. Connect 24VDC Ground "+" from power supply to telephone system GROUND.
- \_\_\_ 4. Power test:
  - \_\_\_ (a) Plug in power supply
  - \_\_\_ (b) If power reversal LED is lit:
    - \_\_\_ (1) Unplug power supply
    - \_\_\_ (2) Reverse connections on pins 29 and 30
    - \_\_\_ (3) Repeat step 4.
- \_\_\_ 5. Unplug power supply

## Centrex, C. O. and PABX Connecting Arrangements

NOTE: Place a check by the arrangement being used and proceed to the Figure indicated for step-by-step instructions.

- \_\_\_ 1. One Zone of One-Way Paging: Proceed to Figure 5.
- \_\_\_ 2. Multi-Zone One-Way Paging with All Call: Proceed to Figure 6.

## WIRING INSTRUCTIONS

Place a check by each step as it is completed.

- \_\_\_ 1. Connect Tip of the PABX, Centrex, or C. O. Line to pin 16 of the STPA.
- \_\_\_ 2. Connect Ring of the line to pin 17.
- \_\_\_ 3. Connect one side of the Tel Line input on the mixer-amplifier to STPA pin 8.
- \_\_\_ 4. Connect the other side of the Tel Line input to pin 9.
- \_\_\_ 5. Dipswitch Settings: If the STPA is being used with a PABX extension, then switch 1 must be OFF. Switch 2 is not used. Turn ON one of switches 3-7 to select the reset timing (the length of time the unit stays active after last sensing audio). Switch 8 must be ON. If the STPA is being accessed from a Centrex or C. O. Line, then set dipswitches 1 and 8 "ON" and switches 2-7 "OFF".

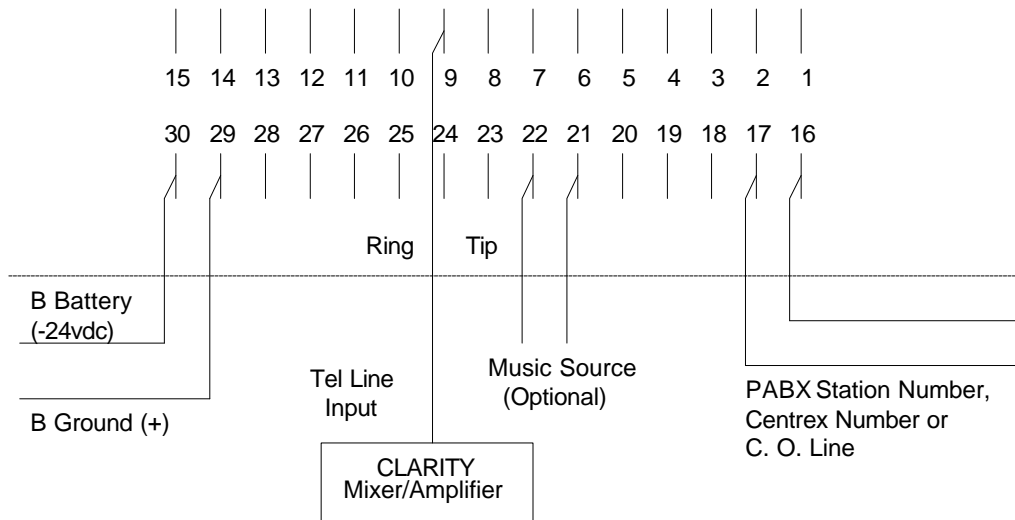

Option switch on Clarity Mixer/Amplifier should be set to Tel Line

Figure 5: One Zone One-Way Paging

**WIRING INSTRUCTIONS:**

Place a check by each step as it is completed.

1. Connections for Zone 1:
  - (a) Connect Tip of the PABX station number for zone one to pin 16 of the STPA being used for zone one.
  - (b) Connect Ring of the station number to pin 17.
- 2. Connect one side of the Tel Line input on the mixer-amplifier to STPA pin 8.
- 3. Connect the other side of the Tel Line input to pin 9.

Remember each zone will require it's own station number and STPA.

- 4. All Call Connections:
  - (a) Connect Tip of the All Call station number to pin 16 of the STPA.
  - (b) Connect Ring of the station number to pin 17.
  - (c) Strap from pin 8 of the All Call STPA to pin 25 of each of the STPA's being used for individual zones.
  - (d) Strap from pin 9 of the all call STPA to pin 26 of each of the STPA's being used for individual zones.
  - (e) Strap from pin 13 of the all call STPA to pin 28 of each of the STPA's being used for individual zones.

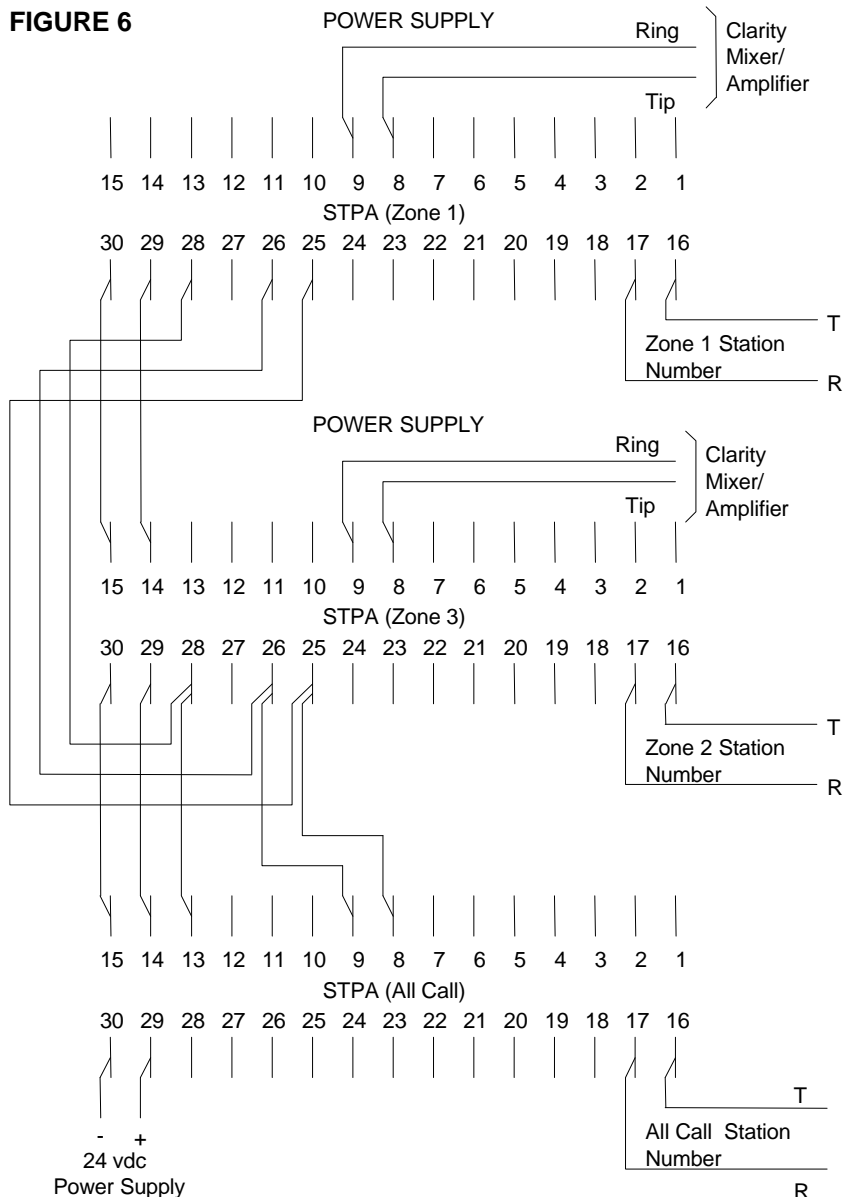

- 5. Dipswitch Settings: If the STPA is being used with a PABX extension, then switch 1 must be OFF. Switch 2 is not used. Turn ON one of switches 3-7 to select the reset timing (the length of time the unit stays active after last sensing audio). Switch 8 must be ON. If the STPA is being accessed from a Centrex or C. O. Line, then set dipswitches 1 and 8 "ON" and switches 2-7 "OFF."

## OPERATION

The STPA, Station Level Page Adapter, has three inputs: Tip and Ring from the line, music, and all call; and two outputs: 8 ohm and 600 ohm.

Any input will provide audio at both the 8 ohm and 600 ohm outputs. Signals coming from the 8 ohm output will be processed by the automatic gain control circuitry and a preamplifier. Music on the 8 ohm output will be maintained 7db below the level of the paging (this is not user adjustable). There is no modification of page or music signals when using the 600 ohm output. The 600 ohm output also provides a loop on access and may be used with loop start paging equipment.

In the idle state, signals from the music input will appear on both the 8 ohm and 600 ohm outputs. On receipt of superimposed ring generator on Tip and Ring, the STPA will be activated and will place a loop across the station Tip and Ring for ring trip. An answer verification tone will then be returned to the calling party, and Tip and Ring audio will be connected to the 8 ohm and 600 ohm outputs.

After access, the reset circuitry is turned on. If the unit is set for loop detect, it will ignore any open conditions for the first second, and then it will release when it senses an open loop on Tip and Ring lasting at least 150 ms. If you are using the audio sense reset, the unit will stay on line until sensing a lack of audio (-22db or less) for the period set by the dipswitches. If using the time out reset, the unit will stay on the line for the preset length of time and then will reset, whether the page is complete or not. On release, the music source is reconnected to the outputs.

All call, if connected, will override both the music and page inputs. All call requires an additional station port for access and must be wired as shown in Figure 4-5. When the all call station number is dialed any paging in progress will be overridden and an alert tone will be returned to the overridden parties. If they remain on the line, on completion of the all call page, they will be reconnected to their respective zones and all timers will be reset, allowing a full page again on each zone.

## TECHNICAL ASSISTANCE

When trouble is reported, verify that DC power is being supplied to the unit. Assistance in troubleshooting is available from the factory. When calling, you should have a VOM and a test set available and be calling from the job site. Call 1-540-427-3505 and ask for an Applications Engineer.

CLARITY equipment is not field repairable. CLARITY maintains service facilities in Roanoke, VA. Should repairs be necessary, please call Clarity at 1-540-427-3505 for a Return Authorization Number.

### LIMITED WARRANTY

Clarity warrants its products to be free from defects in materials and workmanship under conditions of normal use and service for a period of one year from the date of shipment. The obligation under this warranty shall be limited to the replacement, repair or refund of any such defective device within the warranty period, provided that:

1. Inspection by Clarity indicates the validity of the claim;
2. The defect is not the result of damage, misuse, or negligence after the original shipment;
3. The product has not been in any way repaired by others and that factory sealed units are unopened (A service charge plus parts and labor will be applied to units defaced or physically damaged);
4. Freight charges for the return of products to Clarity are prepaid;
5. All units "out of warranty" are subject to a service charge. The service charge will cover minor repairs (Major repairs will be subject to additional charges for parts and labor).

**This warranty is in lieu of and excludes all other warranties expressed or implied, and in no event shall Clarity be liable for any anticipated profits, consequential damages, loss of time or other losses incurred by the buyer in connection with the purchase, operation or use of the product.**

This warranty specifically excludes damage incurred in shipment. In the event a product is received in damaged condition, the carrier should be notified immediately. Claims for such damage should be filed with the carrier involved in accordance with the F.O.B. point.

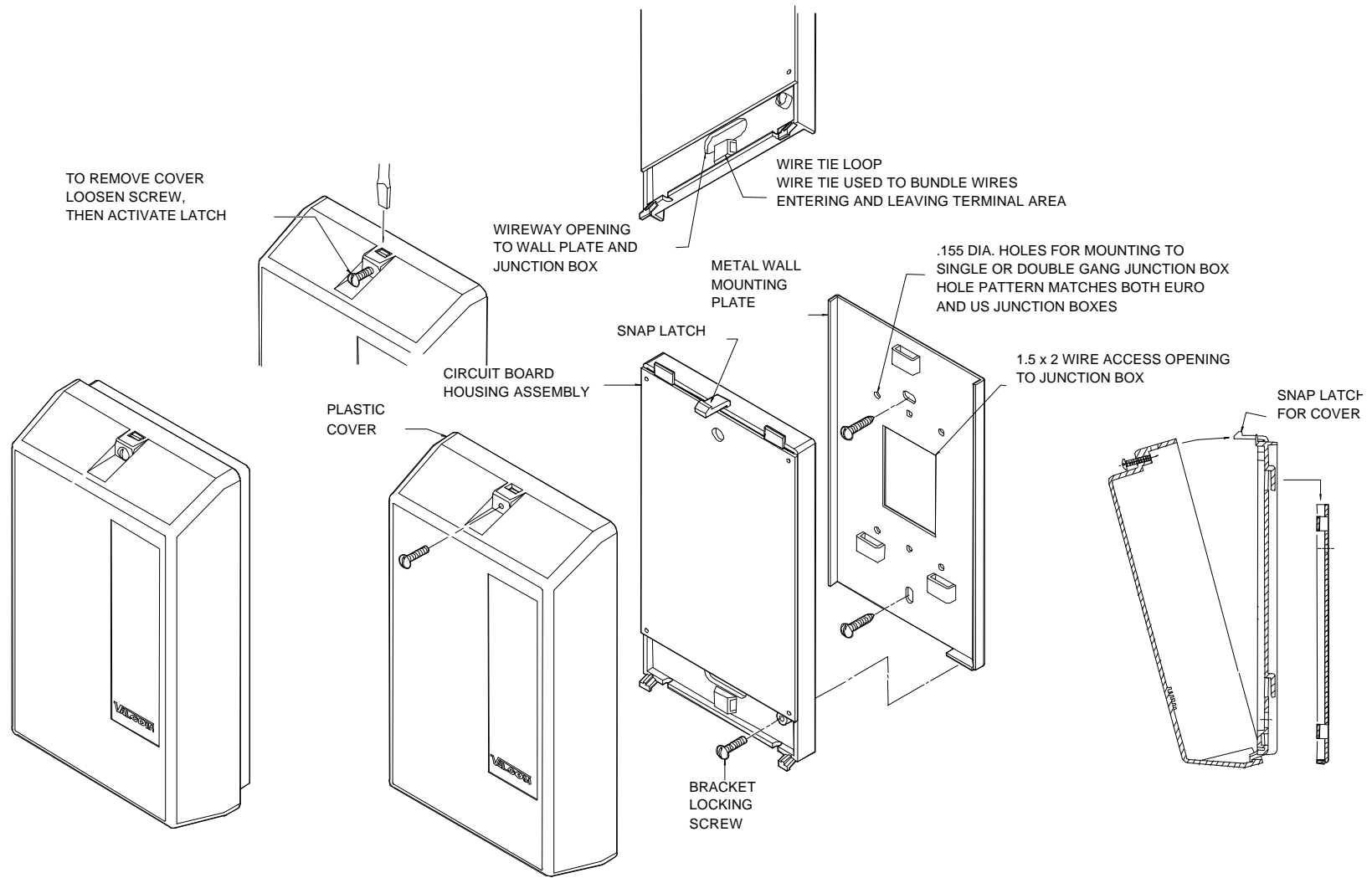

FIGURE 7

<p>1. Red power reversal LED is lit.</p> <p>2. Will not trip ringing.</p> <p>3. No output from amplified speaker assemblies.</p> <p>4. Unit will never release.</p> <p>5. All call does not work</p>	<p>A. Reverse power connections to pins 29 and 30.</p> <p>A. Verify 24 vdc on pins 29 (+) and 30 (-).  B. Verify ring voltage is present on pins 16 and 17 (75 vac min.)</p> <p>A. Listen for audio on 8 ohm output (pins 8 and 9).  B. Verify 24vdc to speakers (GND is +, 24 vdc is -).</p> <p>A. Refer to the appropriate connection Figure and verify dipswitches are set properly.</p> <p>A. Verify connection s according to Figure 6.  B. Verify "all call out" of master unit is connected to "all call in" of all other units.  C. Verify 8 ohm output of master unit connected to "all call audio in" of all other units.  D. Verify proper voltage and polarity on pins 29 (+) and 30 (-) of master unit.  E. Verify ring voltage is present on pins 16 and 17 of master unit when all call number is dialed.</p>
--	--